

# DIRECTIONAL VALVES

## LS04-B30 Load Shuttle, Ball-Type, "Down-Hole" Mount

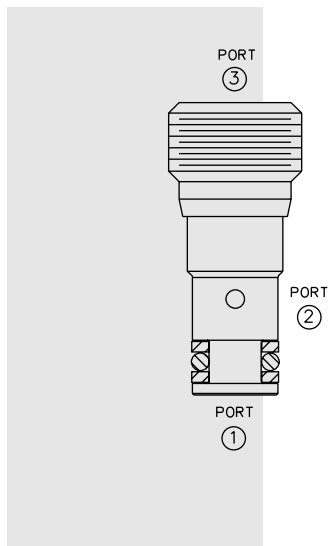

### DESCRIPTION

A load-shuttling, screw-in, cartridge-style hydraulic check valve, for use in blocking circuits where a priority of flow/direction is given to a higher pressure circuit over a lower one.

### OPERATION

The LS04-B30 will allow flow from the higher pressure of ① or ③ port to the ② port. The valve is commonly used to direct oil from the pressure side of a bidirectional hydraulic motor to a pressure-released hydraulic brake. It can also be used as a load-sense signaling valve.

### FEATURES

- Rapid response to load direction changes.
- Miniature size.

### RATINGS

**Operating Pressure:** 240 bar (3500 psi)

**Flow:** See Performance Chart

**Internal Leakage:** 0.25 cc/minute (5 drops/minute) max. at 207 bar(3000 psi)

**Temperature:** -40 to 120°C with standard Buna seals

**Filtration:** See page 9.010.1

**Fluids:** Mineral-based or synthetics with lubricating properties at viscosities of 7.4 to 420 cSt (50 to 2000 ssu)

**Installation:** No restrictions; See page 9.020.1

**Cavity:** VC04-B3; See page 9.104.1

**Cavity Tool:** CT04-3XX; See page 8.600.1

**Seal Kit:** SK04-B3X-M; See page 8.650.1

### SYMBOLS

#### USASI/ISO:

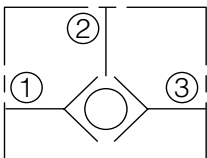

### PERFORMANCE (Cartridge Only)

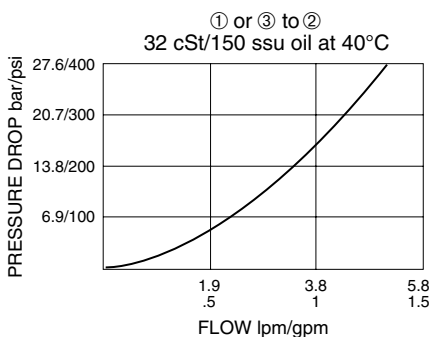

**LS04-B30**

**DIMENSIONS**

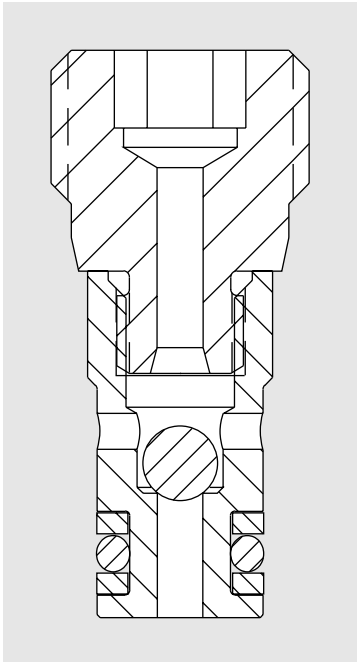
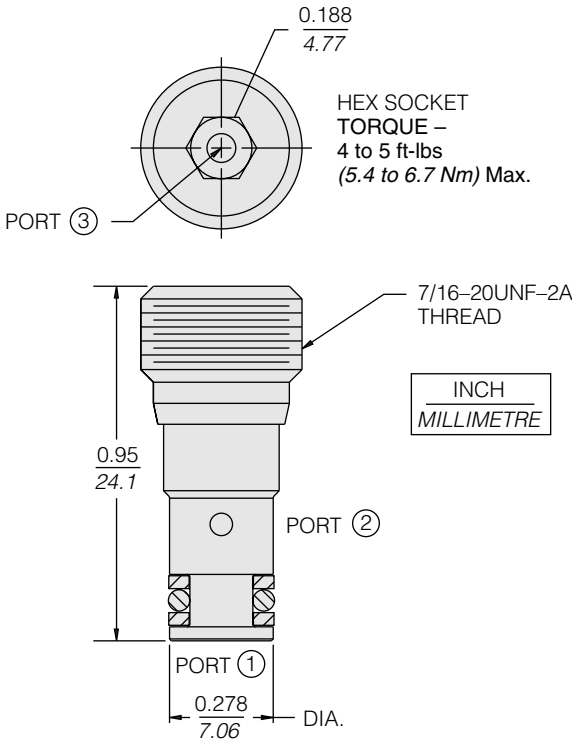

**MATERIALS**

**Cartridge:** Weight: 0.08 kg. (0.17 lbs.);  
Steel; Zinc-plated exposed surfaces;  
Buna N O-rings and back-ups  
standard.

**TO ORDER**

