

# DIRECTIONAL VALVES

## LSV1 Load Shuttle, Ball-Type

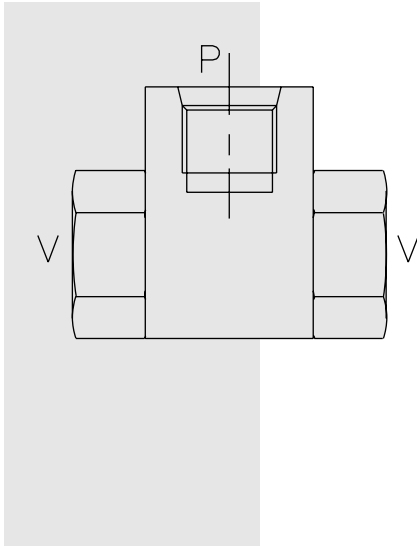

### DESCRIPTION

An in-line plumbed, low leak, load-shuttling hydraulic check valve for use as a directional selector.

### OPERATION

The LSV1 will allow flow from the higher pressure of ① or ③ to ②.

The valve is commonly used to direct oil from the pressure side of a bidirectional hydraulic motor to a pressure-released hydraulic brake.

### FEATURES

- Hardened seat for long life and low leakage.
- Rapid response to load direction changes.
- Compact size.

### RATINGS

**Operating Pressure:** 240 bar (3500 psi)

**Flow:** See Performance Chart

**Internal Leakage:** 0.25 cc/minute (5 drops/minute) max. at 207 bar (3000 psi)

**Temperature:** -40 to 120°C with standard Buna seals

**Filtration:** See page 9.010.1

**Fluids:** Mineral-based or synthetics with lubricating properties at viscosities of 7.4 to 420 cSt (50 to 2000 ssu)

**Installation:** No restrictions

**Seal Kit:** Non-serviceable

### SYMBOLS

#### USASI/ISO:

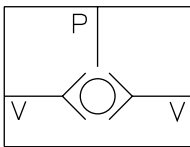

### PERFORMANCE (Cartridge Only)

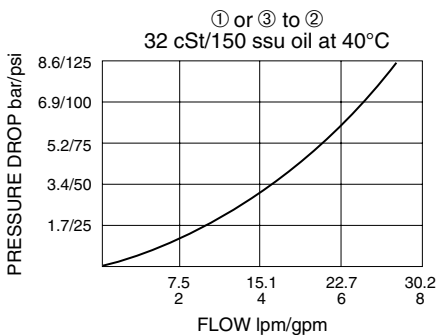

**LSV1**

**DIMENSIONS**

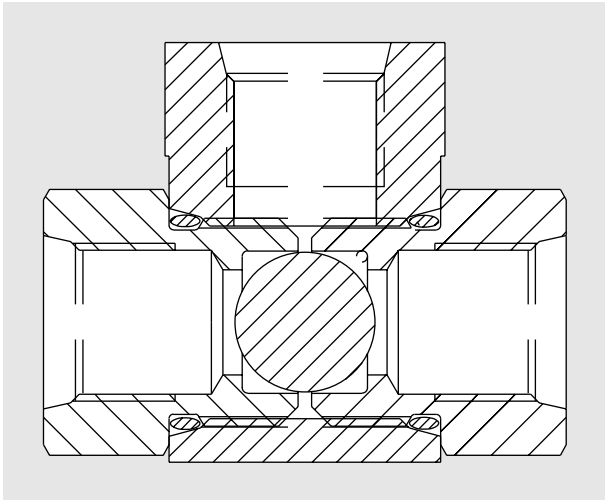
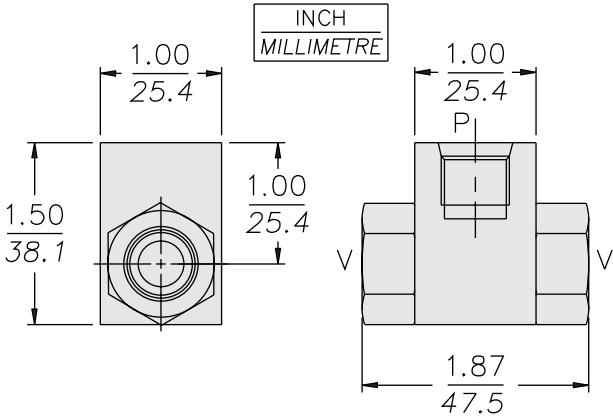

**MATERIALS**

**Internal Parts:** Steel; Zinc-plated exposed surfaces. Buna N O-rings standard.

**Standard Ported Body:** Anodized high-strength 6061 T6 aluminum alloy, rated to 240 bar (3500 psi).

**Weight:** 0.13 kg. (0.28 lbs.).

**TO ORDER**

