

# DIRECTIONAL VALVES

## CV10-23 Check Valve

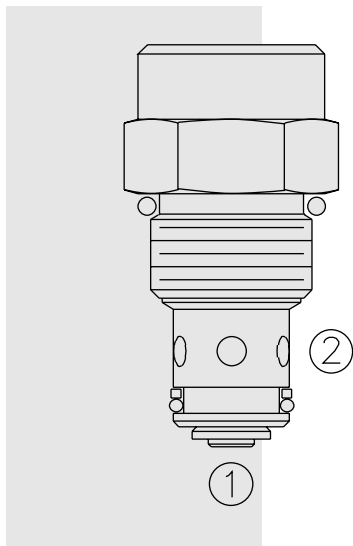

### DESCRIPTION

A screw-in, cartridge-style, hydraulic check valve for use as a blocking or load-holding device.

### OPERATION

The CV10-23 allows flow passage from ② to ①, while blocking flow from ① to ②.

The cartridge has a fully guided check which is spring-biased closed until sufficient pressure is applied at ② to open to ①.

### FEATURES

- Low check mass for anti-cavitation applications.
- Hardened seat for long life and low leakage.
- Optional bias springs for back-pressure application flexibility.
- Industry common cavity.

### RATINGS

**Operating Pressure:** 240 bar (3500 psi)

**Proof Pressure:** 420 bar (6090 psi)

**Flow:** See Performance Chart

**Internal Leakage:** 0.25 cc/minute (5 drops/minute) max. at 240 bar (3500 psi)

**Crack Pressure Defined:** Gauge psi evident at ② at 16.4 cc/minute (1 cu. in./minute) attained at ①

**Standard Bias Springs at Crack:** 0.3 bar (4 psi); 1.7 bar (25 psi); 3.8 bar (55 psi)

**Temperature:** -40 to 120°C

**Filtration:** See page 9.010.1

**Fluids:** Mineral-based or synthetics with lubricating properties at viscosities of 7.4 to 420 cSt (50 to 2000 ssu)

**Installation:** See note in dimension drawing regarding minimum pilot drill diameter. Use of 10-size 2P standard ported body is prohibited.

**Cavity:** VC10-2; See page 9.110.1 (Cavity Variation "A")

**Cavity Tool:** CT10-2XX; See page 8.600.1

**Seal Kit:** SK10-2X-B; See page 8.650.1

### SYMBOLS

#### USASI:

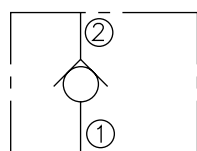

#### ISO:

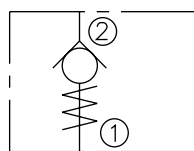

### PERFORMANCE (Cartridge Only)

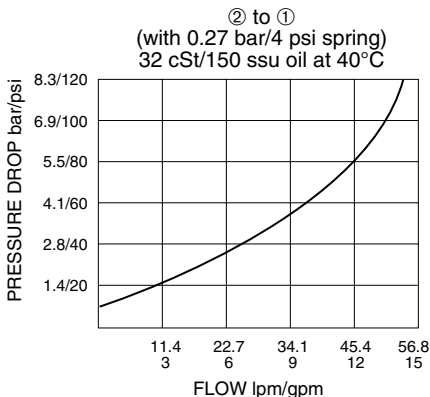

**CV10-23**

**DIMENSIONS**

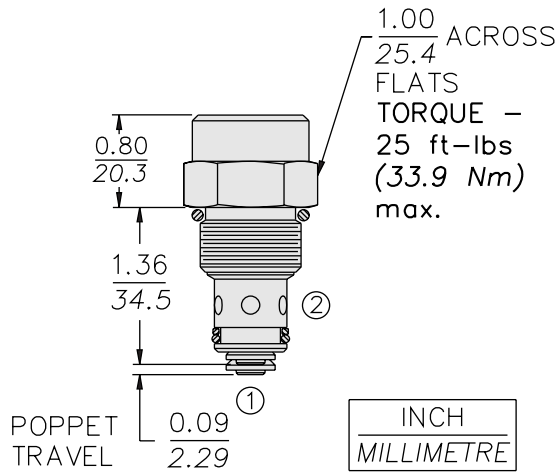

ORIFICE DISC MAY NOT BE USED WITH THIS PRODUCT.

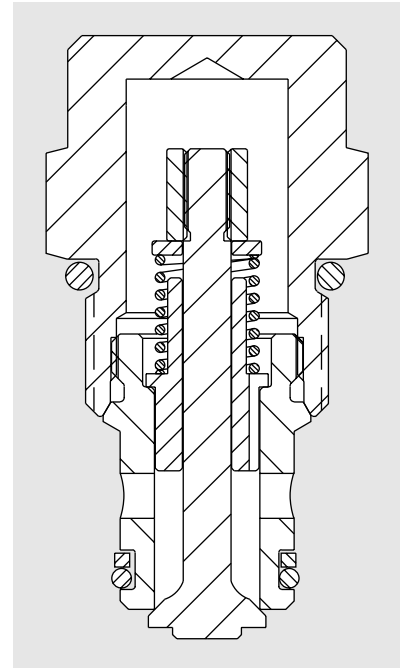

**MATERIALS**

**Cartridge:** Weight: 0.08 kg. (0.17 lbs.);  
Steel with hardened work surfaces;  
Zinc-plated exposed surfaces;  
Buna N O-rings and polyester elastomer back-ups standard.

**TO ORDER**

