

HP10-20 Hand Pump

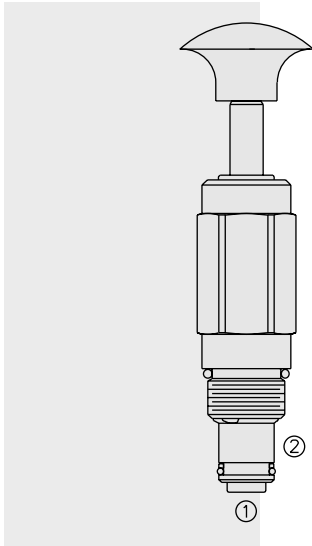

SYMBOLS

USASI/ISO:

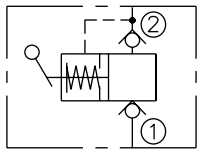

DESCRIPTION

A screw-in, cartridge-style, push and release type hand pump with two built-in checks.

OPERATION

The HP10-20 will provide a specific displacement of oil from port ①.

Note: As with any mechanical hydraulic actuator (piston rods, rotating pump shaft, etc.) the shaft will become coated with a minute amount of oil from the internal high pressure system. The rod protruding from the hand pump may feel damp with oil after use. This is desirable because the oil coating serves to lubricate the shaft seal, reducing friction and assuring extended seal life.

FEATURES

- Hardened parts for long life.
- Heavy duty construction.
- Industry common cavity.

RATINGS

Operating Pressure: Port ① to 207 bar/3000 psi; Port ② to 69 bar/1000 psi

Displacement: 1.36 cc/0.083 cu. in. per stroke

Force Required: 30 lbs. to attain 17 bar/250 psi

Internal Leakage: From port ① to port ②: 0.15 cc/3 drops per minute maximum at 207 bar/3000 psi

Temperature: -40 to 120°

Filtration: See page 9.010.1

Fluids: Mineral-based or synthetics with lubricating properties at viscosities of 7.4 to 420 cSt (50 to 2000 sus)

Installation: No restrictions; See page 9.020.1

Cavity: VC10-2, Variation "A"; See page 9.110.1

Cavity Tool: CT10-2XX; See page 8.600.1

Seal Kit: SK10-2x-T; See page 8.650.1

DIMENSIONS

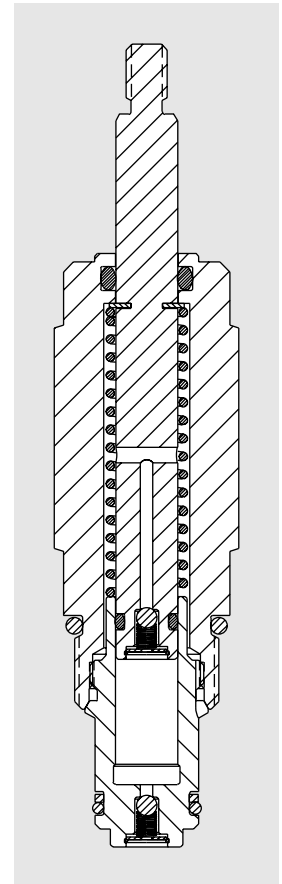
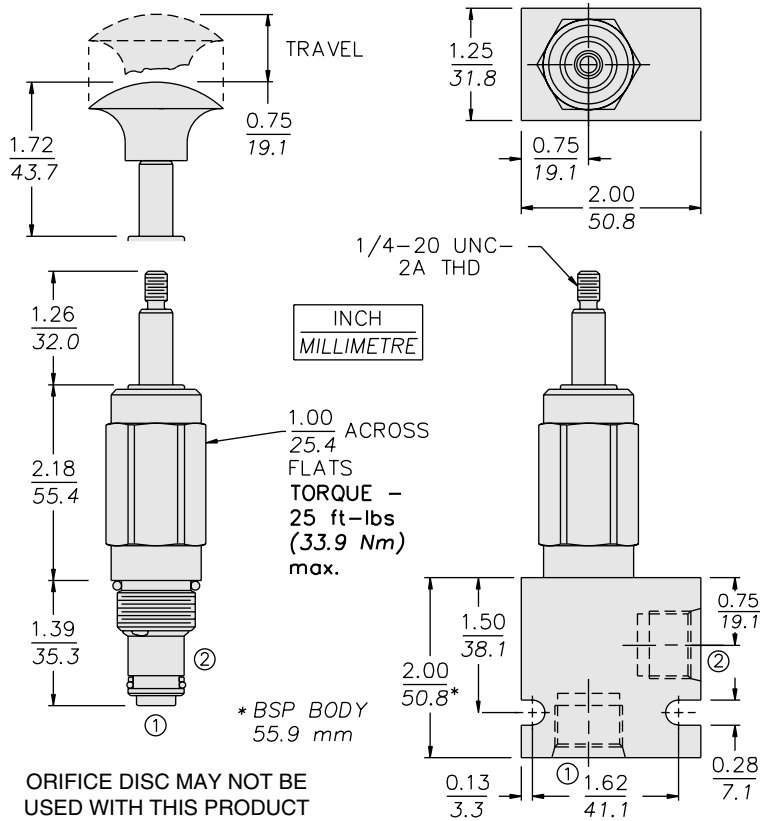

MATERIALS

Cartridge: Weight: 0.27 kg. (0.60 lbs.); Steel with hardened work surfaces. Zinc-plated exposed surfaces. Buna N O-rings and polyester elastomer back-ups standard. Anodized aluminum knobs.

Standard Ported Body: Weight: 0.16 kg. (0.35 lbs.); Anodized high-strength 6061 T6 aluminum alloy, rated to 240 bar (3500 psi); See page 8.010.1. Ductile iron and steel bodies available; dimensions may differ; consult factory.

TO ORDER

